

### VERY IMPORTANT NOTE

This Revotec Cooling Kit has been engineered to provide perfect cooling an original, un-modified MGC. However it is essential the other components of the cooling system are operating correctly.

The following must be checked:

1. The radiator has a normal life expectancy of approx 8-9 Years after this time it should be thoroughly assessed and if there are any signs of deterioration such as furring up internally or it is out of shape it is recommended it is replaced.
2. The Radiator fins Must be clear of all debris such as mud and leaves.
3. The system Must be filled with correct coolant.
4. The water pump and thermostat must be operating correctly.

1. Disconnect +ve battery terminal, drain the water system, remove the top and bottom hoses and remove the radiator/shroud assembly, then remove the original mechanical fan.

2. Using Fig.1 as a guide, slide the studs of lower LH bracket (Item 2) through the lugs on the LH fan (Item 7) then slide 2x 3mm spacers (Item 9) onto each lug, then the upper LH bracket (Item 1) and 2x 6mm washers (Item 11) and fix into place using 2x M6 nuts (Item 12).

3. Slide the studs of lower RH bracket (Item 5) through the lugs on the RH fan (Item 7) slide 2x 3mm spacers (Item 9) onto each lug, then the upper RH bracket (Item 6) and 2x 6mm washers (Item 11) and fix into place using 2x M6 nuts (Item 12).

4. Lay the lower centre bracket (Item 4) on a flat surface and place 2 fan assemblies over the studs to join them together using Fig. 1 as a guide, then slide 4x 7.8mm spacers (Item 8) onto each lug, then the upper centre bracket (Item 3) and 4x 6mm washers (Item 11) and fix into place using 4x M6 nuts (Item 12).

5. **An extra pair of hands will be beneficial at this point.** Lay the radiator front down on a flat surface, then carefully lay the twin fan assembly in position aligning the holes in the brackets with the holes in the radiator. Lower the fans and radiator into position in the car with the fans positioned between the radiator and the engine and using Fig.3 as a guide, mount in place using the 40mm spacers (Item 14) 8mm washers (Item 13) and 63.5mm bolts (Item 10), in the following sequence: radiator, washer, spacer, washer, bracket, washer then bolt.

6. Position the fan controller in a suitable place in the top hose, reconnect and refill the water system, connect the fans in parallel as shown in Fig.4, follow the separate Electronic Fan Controller instructions for information on wiring and setup.

Fig.1

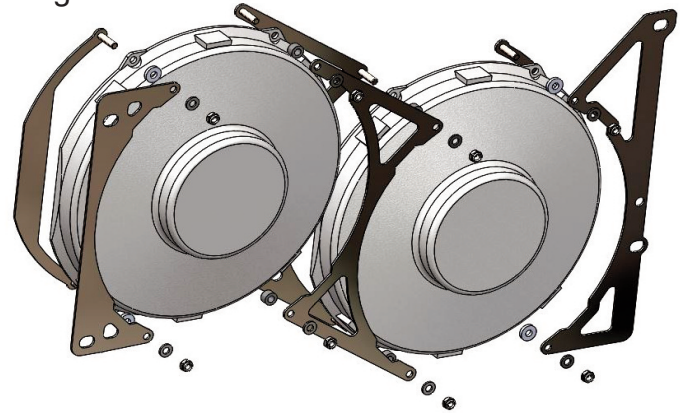

Fig.2

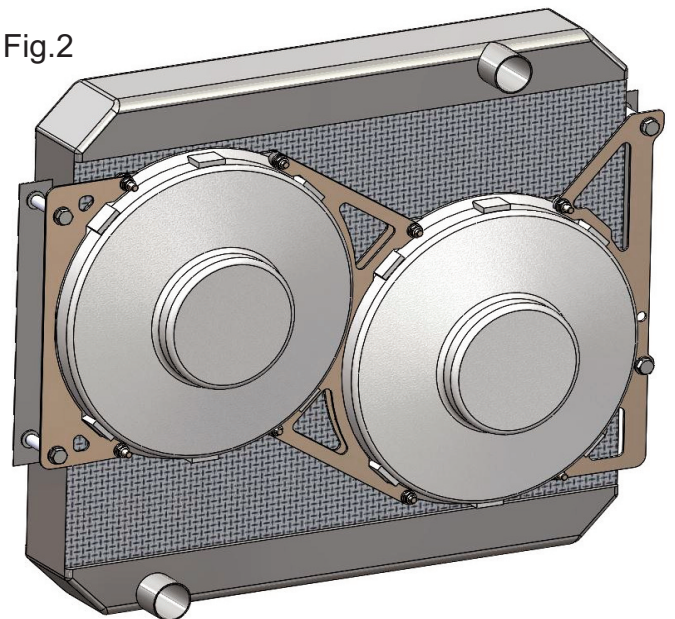

Fig.3

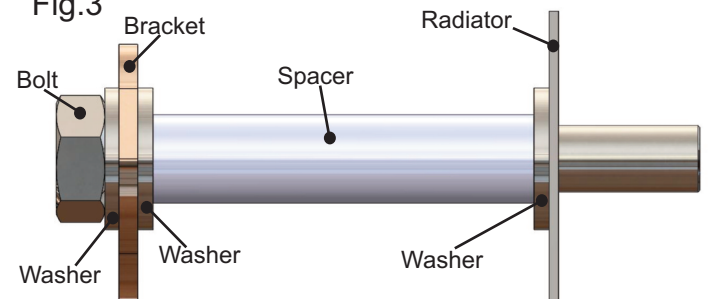

Fig.4

